

Mastercam X⁵ Mill

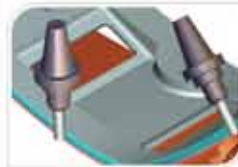
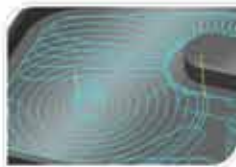

World Class Machining

CNC Software, Inc. is committed to bringing environmentally friendly and socially responsible practices to our industry.

The brochure you are reading has been condensed to decrease paper consumption. These are some of Mastercam's most important highlights, but there's much more information online.

Throughout the brochure, you'll notice some special indicators.

 = Video available online that will give you more details.

Blue text = More descriptive information linked in the electronic brochure.

For complete information on Mastercam Mill, visit www.MastercamMill.com

A Few Simple Clicks Powerful Part Modeling

Mastercam's streamlined CAD engine makes design work easier than ever before. Each piece of geometry you create is "live," letting you quickly make modifications until it's exactly what you want. Some of Mastercam's modeling tools include:

- Easy 2D and 3D geometry creation with complete wireframe and surface modeling.
- Remove trim boundaries and fill trimmed holes.
- Automatic parting line calculation for mold making.
- Associative dimensions update as you change your model.
- Advanced analysis tools to help modeling and programming.
- Solid modeling is available as an optional add-in.
- Built-in data translators for IGES, Parasolid®, SAT (ACIS solids), AutoCAD® (DXF, DWG, and Inventor™ files), SolidWorks® (including history tree), Solid Edge®, STEP, EPS, CADL, STL, and more. Direct translators for CATIA®, Pro/E, and more are also available.
- Special free Mastercam Direct add-ins put a Mastercam launch button in your SolidWorks, Solid Edge, or AutoCAD Inventor toolbars.

Mastercam includes powerful wireframe and surface modeling tools, perfect for creating everything from simple to complex models. Mastercam also gives you easy tools for prepping incoming CAD files.

Intelligent Machining

As the world's most widely-used CAM software*, Mastercam is dedicated to making your entire process easier from start to finish. Here are just a few of the things Mastercam offers to help you make the most of your time.

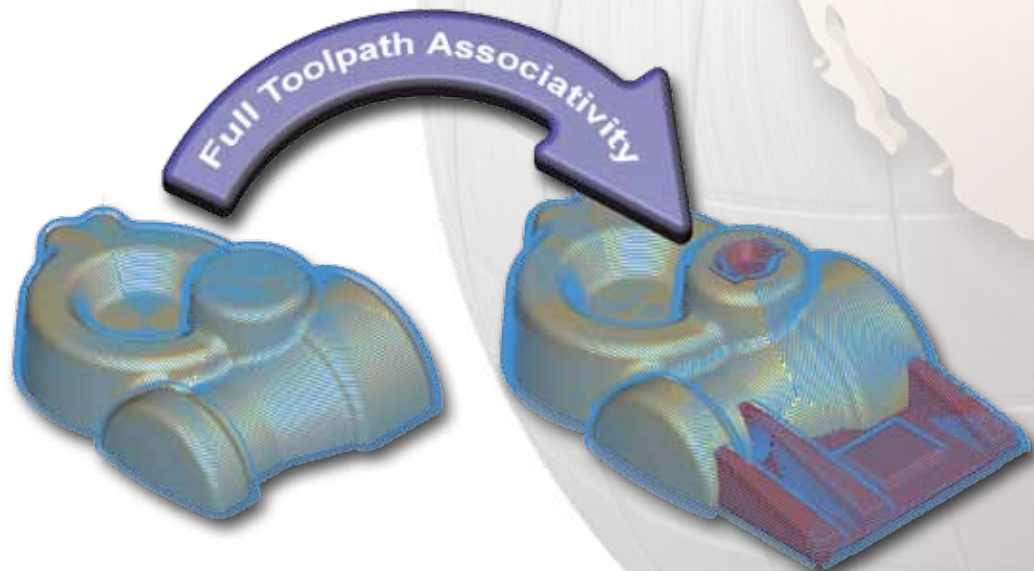

Capture Your Machining Knowledge

Mastercam's full associativity gives you the power to capture your work and build on your experience. Once you program a part—no matter how complex—you can modify any element of the job, and immediately get updated toolpaths without starting over. You can also build a library of your favorite machining strategies. Choose any of your saved operations, apply them to a part, and Mastercam helps adapt them to the new model. It's fast, easy, and productive—the way programming should be.

CAD File Change Recognition and Toolpath Updating

Mastercam's File Tracking and Change Recognition give you an easy way to identify CAD edits and updated cutter paths. Create a checklist of files including Mastercam, SolidWorks, AutoCAD, or other CAD files. Mastercam alerts you when new versions of the files are available and identifies any changes. With a few mouse clicks, you can immediately locate and program these changes, saving valuable time. Plus, you will always be sure your CAM program is based on the latest version of the CAD model.

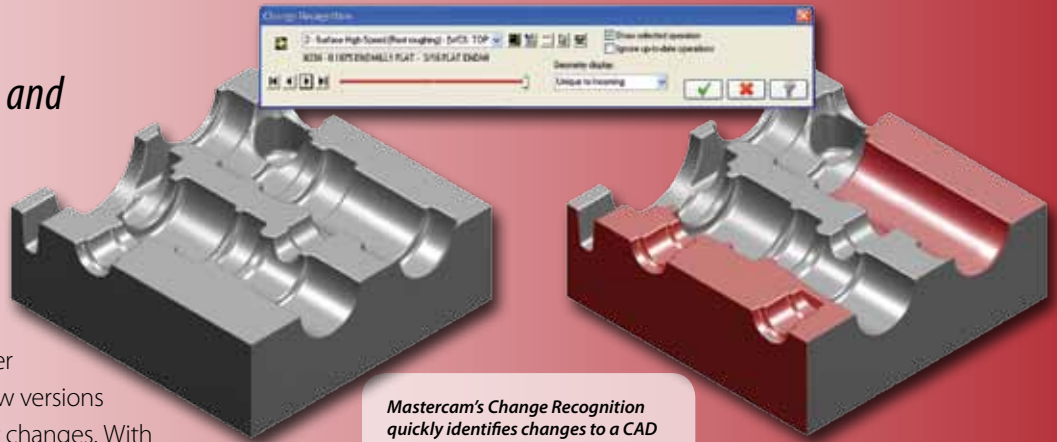

Mastercam's Change Recognition quickly identifies changes to a CAD file, allowing you to easily adjust the toolpath for the updated model.

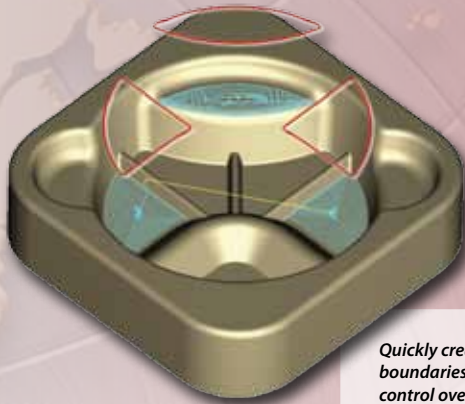

Quickly create toolpath boundaries for additional control over the final cut.

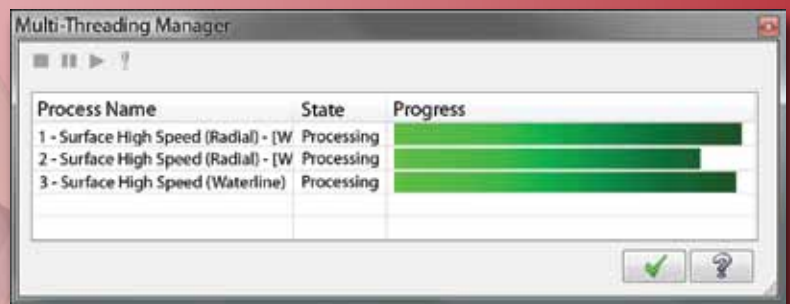

Multi-threading lets you work while complex toolpaths are processing.

Dependable Toolpath Verification and Machine Simulation

Knowing your results before committing tool to material is crucial. Mastercam gives you several ways to ensure that your part will come off the machine exactly as you intended. These include full machine simulation, solid-model verification with tool and holder checking, and toolpath backplotting. These tools deliver vital information about every aspect of the tool motion so you know for sure that what you see is what you get.

Full machine simulation delivers a practical view of how your toolpaths interact with your equipment.

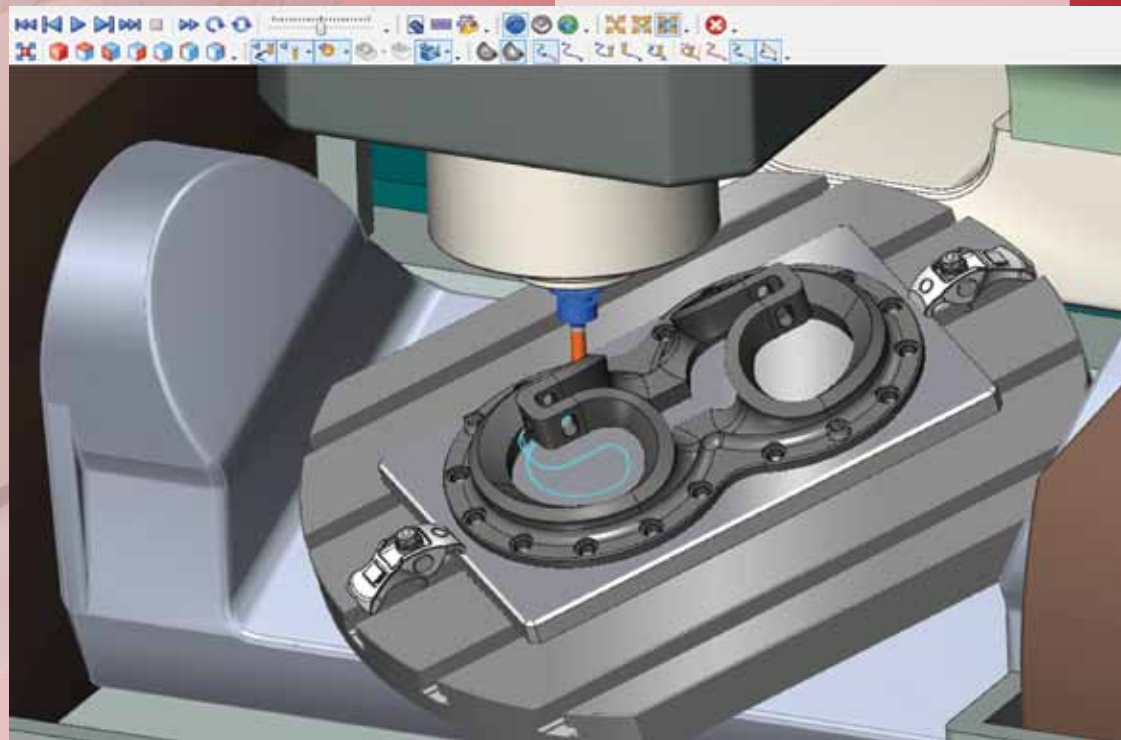

2D Toolpaths **Contouring, Drilling, and Pocketing**

2D machining ranges from the very simple to the very complex. Mastercam delivers all the tools you need for these operations. Highlights include:

- **Dynamic Milling** creates an active toolpath that delivers more consistent cutting conditions and allows use of the entire tool flute length, while reducing machining time.
- **Feature Based Machining (FBM)** automatically programs a solid model's pockets, contours, and drilling routines, including new slug cutting and hole mapping.
- Standard **pocketing styles** include zigzag, one way, true spiral, constant overlap spiral, "morph" pocketing, and open pocketing.
- Choose plunge, helical, or ramp entry.
- Contour and **pocket remachining** use smaller tools to automatically clean out material left from previous operations.
- Specialized support for ISCAR® High Efficiency Machining tool set.
- Ability to click and drag a machining start point to anywhere on your model.
- Automated slot, circle, and thread milling.
- Controlled engagement facing removes stock using a consistent tool load.
- Automatic identification and pre-drilling of multiple operations at their plunge points.
 - Automatic drilling and countersink depth calculation.



"I went through the formal evaluation and approval process here at JPL, and I thought Mastercam would be a good fit. I also noticed that almost every resume that came across my desk had Mastercam experience. Since bringing it in, Mastercam has been nothing but a plus, plus, plus for us."

Richard Cournoyer
Group Supervisor
Jet Propulsion
Laboratory
Pasadena, CA

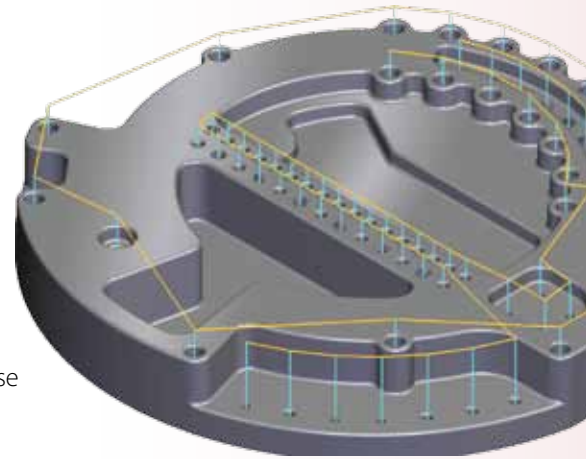
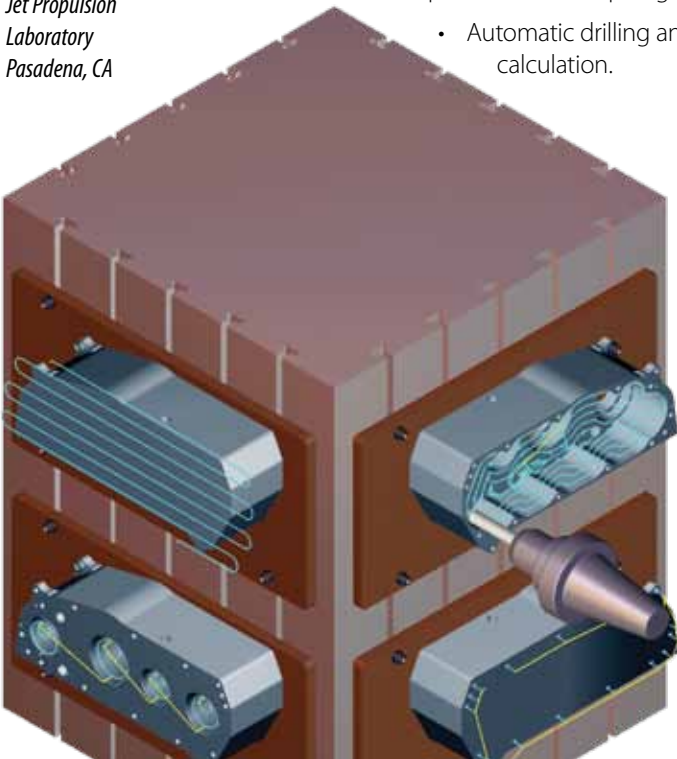

Fully optimized drilling.

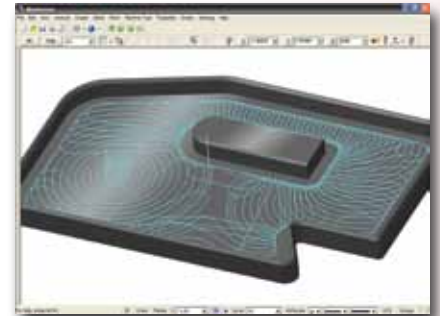

Dynamic Milling creates an active toolpath that delivers more consistent cutting conditions and allows use of the entire tool flute length.

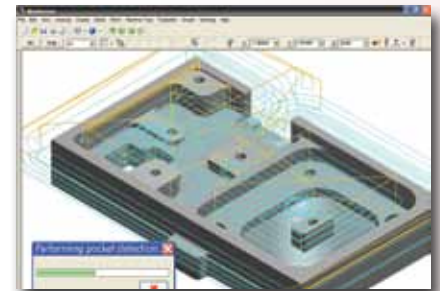

Feature Based Machining makes it significantly easier to machine prismatic solids by automating the programming process.

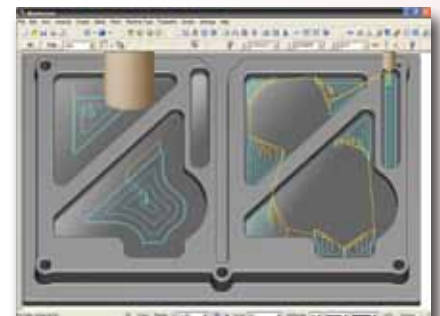

Automated pocket remachining with a smaller tool.

Easy tombstone programming.

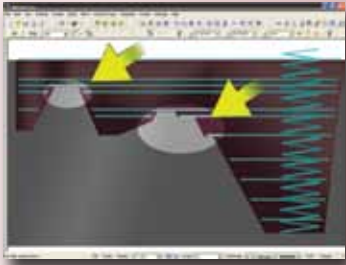

Automatic roughing of critical depths.

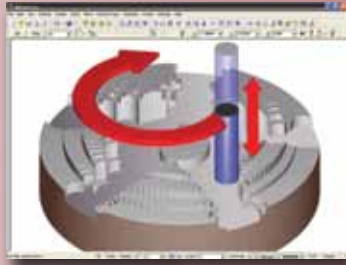

Advanced plunge roughing in any pattern.

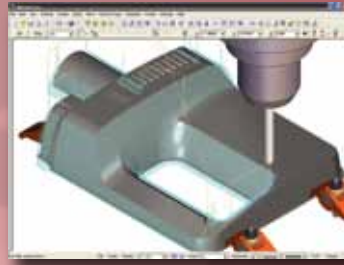

Remachining stock cleanup in steep and shallow areas.

3D Toolpaths

Roughing, Finishing, & Cleanup Machining

Operations that quickly deliver a clean and precise finished part are essential to efficient NC programming. Here are just a few of Mastercam's popular 3D machining techniques:

- Cut multiple surfaces, solid models, or a combination of both.
- **High speed OptiRough** removes large amounts of material quickly. The tool takes an aggressive depth cut, followed by a series of quick up-cuts, then repeats the process at the next depth.

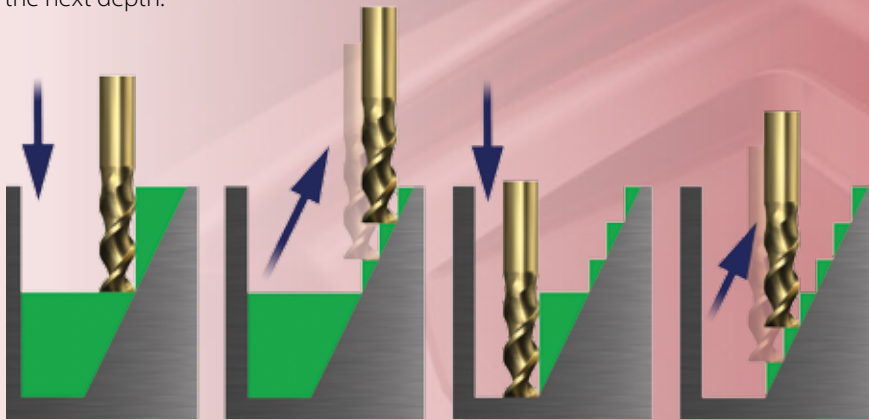

Remove bulk material faster and with more even tool wear.

- **3D Toolpath Refinement** allows unsurpassed control on surface cuts, delivering superior finishes and optimized cycle times.
- **Constant-Z rough (remachining)** identifies and machines areas that need to be roughed with a smaller tool.
- 3D "projected" machining creates a consistent, smooth finish while following the natural curves of the geometry.
- **Constant scallop machining** maintains a consistent finish on sloped and flat surfaces alike by using a consistent 3D stepover.
- Full check surface support.
- **Smart hybrid finishing** and **hybrid leftover machining** each create a single toolpath that changes cut methods as the slope of the model changes.
- Constant-Z rest milling (remachining) identifies and machines areas and critical depths that need to be cut with a smaller tool.
- **Pencil tracing** walks a tool along the intersection of surfaces to clean out hard-to-reach areas. You can perform single or multiple passes for precision cleanup.
- Go to www.MastercamMill.com for more.

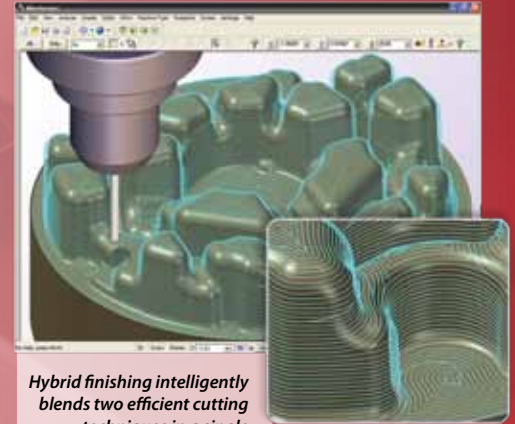

Hybrid finishing intelligently blends two efficient cutting techniques in a single toolpath.

Conventional Finishing



Refined Finishing



3D Toolpath Refinement delivers a dramatically superior finish.

A Wide Range of Strategies

Multiaxis Machining

Multiaxis machining can dramatically increase a shop's competitiveness. Mastercam offers a wide range of multiaxis machining strategies. With Mastercam, you have complete control over the three crucial elements of multiaxis machining: cut pattern, tool axis control, and collision avoidance.



"We use Mastercam's high speed machining to hit the sweet spot where machining is accurate, fast, and least abusive to the machine. We recently shaved 26 hours off three runs of a part, turning it from a low-profit to a high-profit job."

John Graney
Surface Solutions Inc.
Ipswich, MA

Some highlights of Mastercam's multiaxis machining:

- **Multisurface 5-axis** roughing and finishing (including depth cuts), plunge roughing, and flowline machining and drilling.
- Swarf fanning and swarf machining over multisurface floors, plus "rail" swarf cutting for added control.
- **Machine 5-axis curves** with independent definitions of tool side angle and lead/lag angle.
- Create 5-axis contour toolpaths for applications such as trimming vacuum-formed parts.
- Easy 4-axis rotary axis and rolldie programming, and 5-axis drilling.
- 5-axis circle milling.
- Minimum tilt control helps prevent tool motion that would cause tool holder collisions.
- Create full 5-axis motion from a 3-axis toolpath.
- Triangular mesh toolpaths dramatically expand your cutting options.
- Special options for machining cylinder heads and converting probe data to machinable geometries.
- **Advanced gouge checking** and a 5-axis "safe zone" around the part.
- Complete control over the tool axis, lead/lag, entry/exit, and tilt. These simplify even the most difficult multiaxis jobs.
- See a complete list of multiaxis tools at www.MastercamMill.com

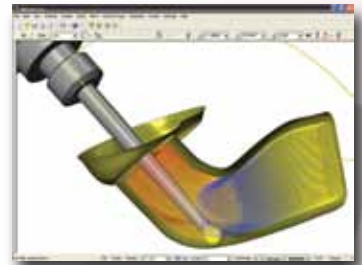

Shank containment simplifies working in confined spaces.

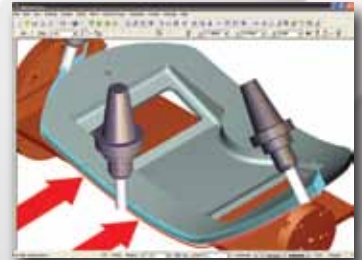

"Rail" swarf cutting lets you control the cut using a lower rail.



Specialized toolpaths support fast, efficient 5-axis drilling.

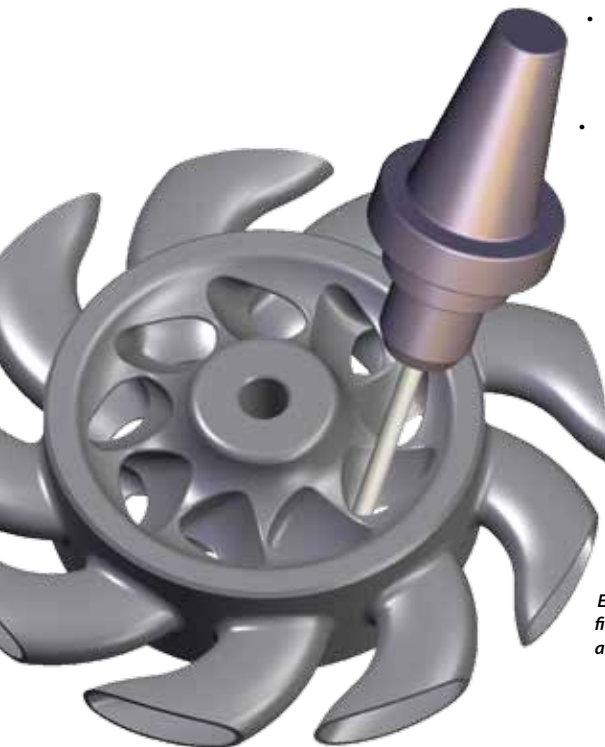

Efficient multiaxis roughing and finishing help ensure accurate cuts and short turnarounds.



Streamlined multiaxis programming tools make projects easier than ever before.

Feed rate optimization
can save up to 35% in
machining time over
non-optimized toolpaths.

Faster Turnaround and Superior Finish

High Speed Machining/Feed Rate Optimization

High Speed Machining (HSM) is a powerful cutting method that combines high feed rates with high spindle speeds, specific tools, and specialized tool motions aimed at producing ultrasmooth movement and cutting action. HSM can deliver faster turnaround and a superior finish. Mastercam includes HSM toolpaths designed to help you make the most of this powerful technique, even if you don't have a high speed machine.

Mastercam also delivers another powerful way to get the most out of your machines. As every shop owner knows, running an entire job at a single feed rate reduces efficiency. Running the same job at varying optimal feed rates can save time and money, and reduces tool wear. Our **Feed Rate Optimization** feature enhances any 2-axis or 3-axis toolpath based on the volume of material being removed and machine tool limitations; more material and the cutter moves slower, less material and the cutter moves faster. Feed Rate Optimization will also automatically ease the tool in and out of corners. The result is efficient, varied feed rates tailored to each job.

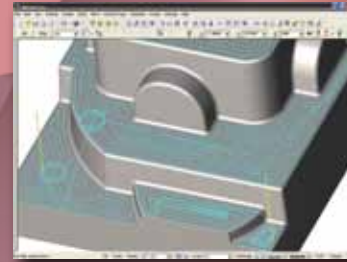

Automatically machine flat areas using new time-saving minimum retracts and smooth entry, exit, and cut motion.

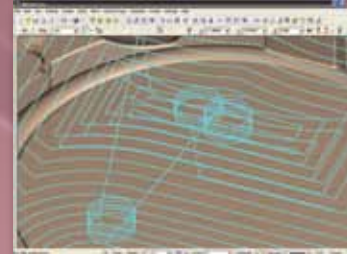

High speed area clearance removes bulk material from the inside-out with smooth motion.

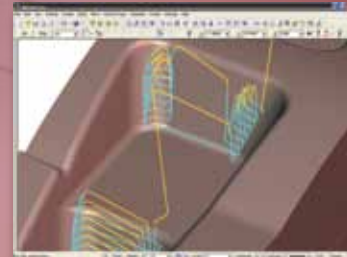

High speed rest roughing smoothly removes material left from a previous rough pass.

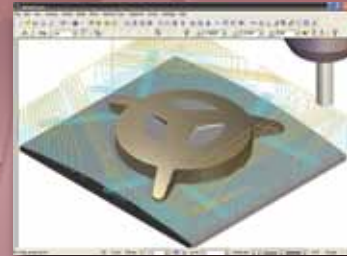

Smart core roughing cuts from the outside-in. If it encounters a pocket, it automatically switches to inside-out.

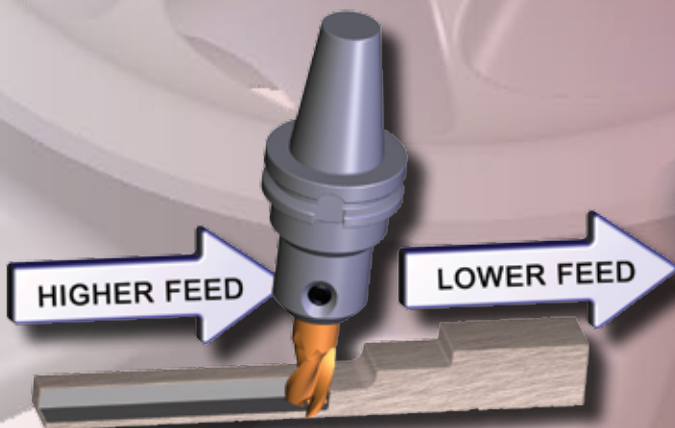

Constant volume removal: Mastercam slows the feed rate through deep material and speeds it up through more shallow stock.

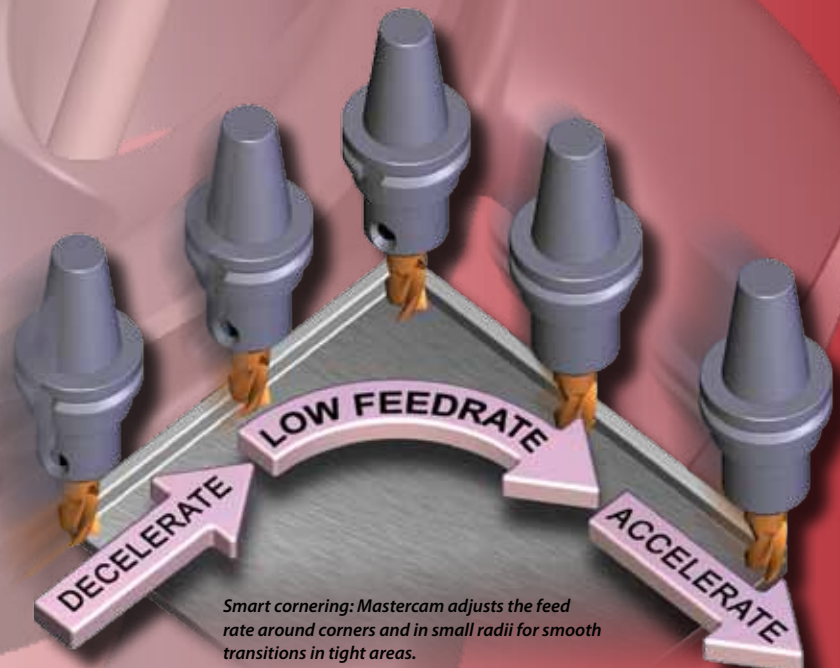

Smart cornering: Mastercam adjusts the feed rate around corners and in small radii for smooth transitions in tight areas.

Specialized Options

Very often, that little something extra—that one additional CAD or CAM tool—makes a specific job easier, faster, and more profitable.

Mastercam offers a set of specialized add-in options for these occasions, including:

- Automatic separation of surface model into core and cavity, including draft angle analysis and identification of problem surfaces.
- Use of point data to create surfaces or STL data for reverse engineering and manufacturing.
- Sophisticated tools for traditional blueprint and CAD-based inspection.
- Automated complex shutoff and parting surface creation.
- Automated EDM electrode creation, including a library of definable stock sizes and materials.
- See a full list at www.Mastercam.com/Products/Addins.

Other powerful CAD/CAM packages available from Mastercam:



Mastercam Lathe

Fast, flexible CNC turning

Mastercam Wire

2-axis and 4-axis wire EDM programming

Mastercam Router

Quick and easy CNC routing

Mastercam® for SolidWorks®

NC programming within SolidWorks

Mastercam Art

Turn flat line art into artistic 3D work

Mastercam Solids

Powerful Parasolid®-based part modeling

Mastercam University™

Online Mastercam Training

System Requirements

- **Processor:** 2.5 GHz (minimum) 32-bit or 64-bit Intel®-compatible processor; 64-bit Intel®-compatible processors are supported.
- **Operating System:** Windows® XP, Windows Vista® (Business or Ultimate), or Windows 7 (Ultimate or Professional) including the latest service packs and recommended updates.
- **Memory:** 2 GB (minimum), 3 GB available hard disk space (minimum).
- **Graphics:** 256 MB OpenGL-compatible graphics card, 1280x1024 pixel screen resolution (minimum).
- **Mouse:** Windows-compatible 2-button or 3-button mouse (or with middle mouse wheel).

	Mastercam Mill	Level 1	Level 2	Level 3
CAD				
Complete customizability		x	x	x
Create and dimension live wireframe geometry		x	x	x
Read/write IGES, DXF, SAT, Parasolid, EPS		x	x	x
Read native AutoCAD, SolidWorks, Solid Edge		x	x	x
Read native CATIA, Pro/E, Unigraphics (UG NX)		Optional	Optional	Optional
Live surface modeling		x	x	x
CAD File Change Recognition		x	x	x
Solid modeling		Optional	Optional	Optional
CAM				
Fully associative toolpaths		x	x	x
Dynamic Milling		x	x	x
Feature Based Machining		x	x	x
Automated Feed Rate Optimization		x	x	x
Contouring, pocketing, and drilling		x	x	x
2D High Speed Machining		x	x	x
3D contour cutting, trimming, and remachining		x	x	x
On-screen toolpath verification		x	x	x
Safety zones for all toolpaths		x	x	x
Machine and control definition		x	x	x
Engraving		x	x	x
Raster to Vector image conversion		x	x	x
Single and limited multisurface roughing			x	x
Single and limited multisurface finishing			x	x
Full multisurface and solid roughing				x
Full multisurface and solid finishing				x
Full multisurface and solid "cleanup" machining				x
Full multisurface and solid High Speed Machining				x
Full multisurface and solid OptiRough cutting				x
Full multisurface and hybrid finishing				x
5-axis drilling and curve machining		Optional	Optional	Optional
Simultaneous 4- and 5-axis machining				Optional

Mastercam® and Mastercam University™ are registered trademarks of CNC Software, Inc. ©Copyright 1983-2011. All rights reserved.
SolidWorks is a registered trademark of DS SolidWorks Corporation.
ISCAR is a registered trademark of ISCAR, Ltd. All other trademarks are property of their respective owners.

Mastercam
cnc software, inc.

671 Old Post Road Tolland, CT 06084 USA
(800) 228-2877 • (860) 875-5006 • Fax (860) 872-1565
www.mastercam.com • mcinfo@mastercam.com